

FIRESTAR[®] MODELS 540 / 550

FIRE-RATED COUNTER SHUTTERS



A REVOLUTIONARY COUNTER SHUTTER THAT LOOKS GREAT WHILE PROVIDING FIRE-RATED PROTECTION AND UNIQUE TESTING FEATURES.

The FireStar[®] Fire-Rated Counter Shutters meet the demands of applications that require a pleasing appearance combined with certified and labeled fire protection for your property. Our innovative and exclusive design provides lift-up operation that is extremely easy to test and does not require tools to reset the mechanism. As an added bonus, the design offers very quiet and smooth functionality.

Firestar[®] Fire-Rated Counter Shutters are an ideal choice for schools, concessions, hospitals, cafeterias and retail settings.

- » STANDARD SIZES UP TO 16' WIDE AND 9' HIGH
- » EASY TO TEST
- » NON-TENSION RELEASE
- » FLOOR RESETTABLE
- » QUIET OPERATION
- » UL/ULC/FM RATED
- » CONFORMS TO NFPA 80 STANDARD
- » FIRE-RATED COUNTER TOPS

FIRESTAR® MODELS 540 / 550

STANDARD FEATURES OVERVIEW

CONSTRUCTION

MAX HEIGHT	9' (2743 mm)
MAX WIDTH	16' (4877 mm)
MATERIAL	Model 540: 22-gauge galvanized steel primed and painted Model 550: 22-gauge stainless steel #4 finish
CURTAIN	Interlocking roll-formed slats with alternate slats fitted with metal endlocks
BOTTOM BAR	Steel single angle (540 galvanized steel; 550 stainless steel with #4 finish)
BRACKETS	Steel plates enclose ends of coil and provide support for counterbalance pipe at each end
COUNTER BALANCE	Curtain to be balanced by helical springs, oil tempered torsion type. Cast iron barrel plugs will be used to anchor springs to tension shaft and pipe. 20,000 cycle
HOOD	24-gauge galvanized steel with paint (540) or stainless steel (550) hood
FINISH	Rust inhibitive primer on non-galvanized surfaces and operating mechanisms. Guides and brackets will be coated with a flat black prime paint
OPERATION	Manual lift-up standard
RELEASE MECHANISM	FireStar® release mechanism standard on shutters up to 24' x 24'
VISCOUS GOVERNOR	If required by size of door
MOUNTING	Steel, masonry, fire rated wood, fire rated drywall, 16 + gauge steel jambs
WARRANTY	Two (2) Year Limited

OPTIONS

- 540: 20-gauge galvanized steel primed and painted
- Vision FireLites®*
- FM label option to include hood with steel baffle
- Chain hoist with gear drive reduction
- Wall crank box
- Motor operation
- Electrical or pneumatic sensing edge
- Fire-rated counter top
- Powder coat finish
- Smoke seal
- Waynegard™ Release System
- Horns and strobes
- Smoke detector

*FireLite is a trademark of Nippon Electric Glass Company

FireStar® Fire-Rated Counter Shutters are a simple and innovative solution for your safety and fire protection needs.

Critical elements necessary in the reliable function of fire doors are incorporated as standard features with the FireStar® revolutionary design.

By eliminating one of the fusible link cables, the door and surrounding area look cleaner and less cluttered. It also reduces the risk of cable interference with other nearby fixtures while making installation and drop testing easier.

EASY MAINTENANCE

Unique clean design eliminates excess cables for ease of installation, testing and maintenance.



NO. 17

Flat-faced slat in 22-gauge steel or stainless steel.

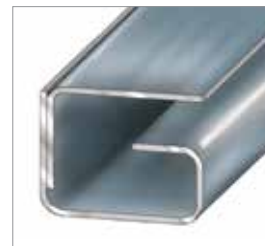

GUIDE ASSEMBLY

Sleek 2-piece guide assembly provides better aesthetic appeal and allows for easier installation.

FIRE-RATED COUNTER SHUTTERS



SAFETY

The FireStar® counter shutter can be drop tested easily and reset in a matter of seconds at any time, no tools or service technicians are required.

Drop testing can be done in addition to the doors required annual inspection by a trained door systems technician.

By self-testing throughout the year, facility personnel can be even more confident that their door will function safely in the event of fire.

ACCESSORIES



Waynegard™
Release Systems



Horns and strobes



Smoke detectors

OPTIONAL FIRE RATED COUNTER TOP

For maximum fire protection, use our fire-rated countertops.

- Interior core - Georgia Pacific Firestop® composite and high density particle board.
- Finish - All colors can be selected by architect through various brands of plastic laminate.

RELIABILITY

FireStar® Counter Shutters are tested and approved to meet the requirements of Underwriters Laboratories, Factory Mutual, and NFPA 80 Standard.





Test Device – FireStar® doors feature an easy-to-use release handle.

FIRESTAR® DOOR CONTROL DEVICES

Chain hoist and motor operation

- Revolutionary fire door control device utilizing a planetary gear arrangement to disconnect the operator and drop the door in the event of a fire.
- Easily drop test and reset a fire door without resetting spring tension and rerouting cables.



Lift-up and crank operation

- Revolutionary fire door control device utilizing clutch plates and unique counterbalance technology to drop the door in the event of a fire.

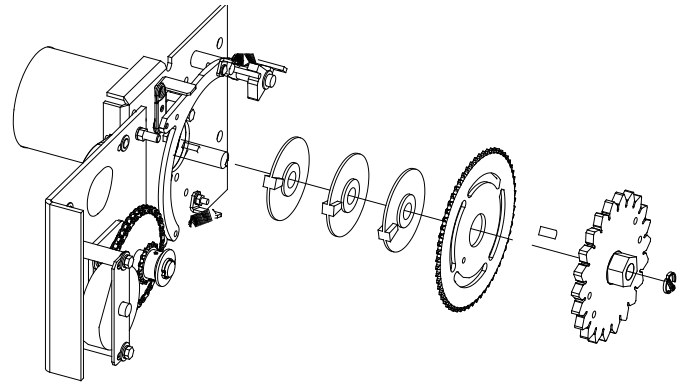

Architect Resource Center

Go to wayne-dalton.com/commercial and click on the Architect Resource Center. Here you will quickly find all of the specifications, drawings and documents you need to complete your project.

Wayne Dalton
COMMERCIAL DOORS

DISTRIBUTED BY:

2501 S. State Hwy 121 Bus., Ste 200
Lewisville, TX 75067

wayne-dalton.com



©2016 Wayne Dalton, a division of Overhead Door Corporation. Consistent with our policy of continuing product improvement, we reserve the right to change product specifications without notice or obligation. Item 344969 1M 06/16 JAR