

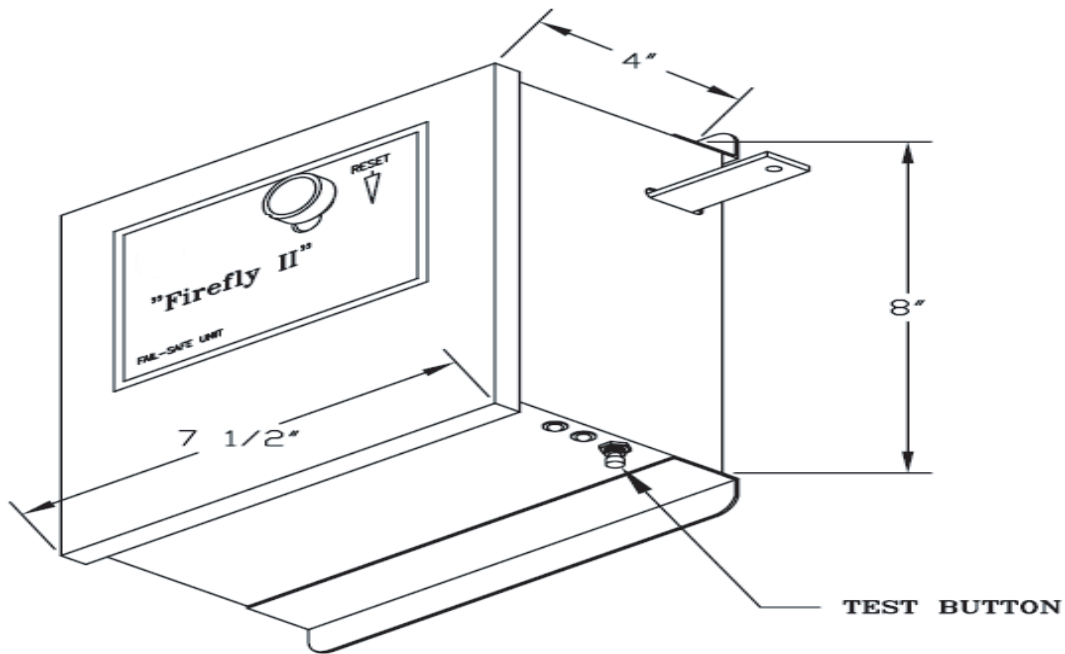

For all the “*Rite*” Loading Dock Solutions

FIREFLY II MV (MULTI-VOLTAGE RELEASE DEVICES)

Electrical Charts



Electrical Requirements

INPUT VOLTAGE	VOLTAGE REQUIREMENTS	CURRENT REQ'D SUPERVISORY *	CURRENT REQ'D ALARM CONDITION
120VAC	120VAC ± 10%	0.3A	0.65A
24VAC	24VAC ± 5%	0.075A	0.130A
24VDC	24VDC ± 5%	0.025A	0.045A

* NOTE: Initial power up in rush current not to exceed 3 times rated current

ELECTRICAL CONNECTIONS (TYPICAL)

FOUR WIRE - INDEPENDENT ALARM & POWER LOSS DELAYS

Reference all footnotes below for additional installation information

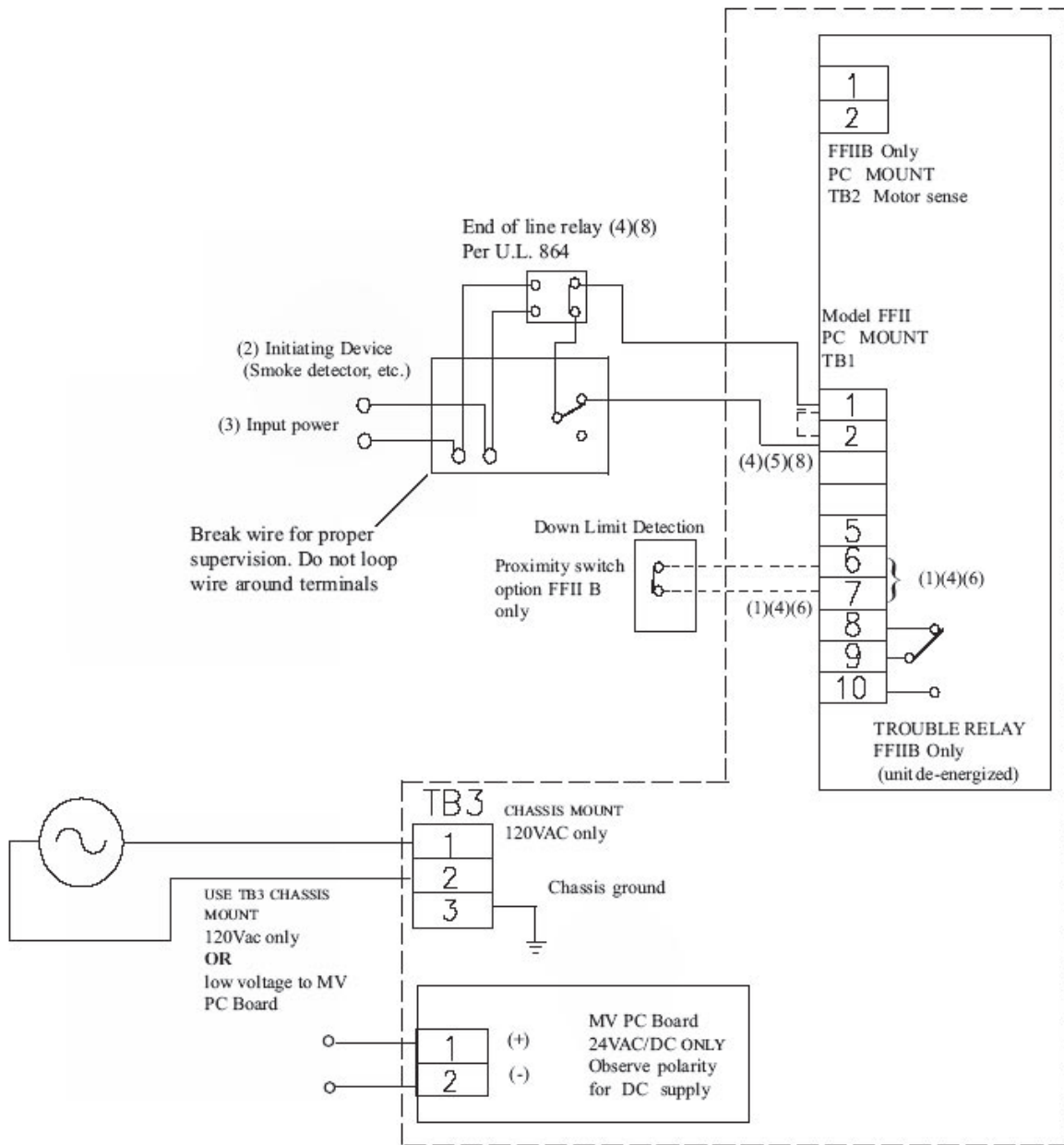

- (1) Dotted line indicates factory jumper which must be removed when connecting the N/C device
- (2) See NFPA 80 and NFPA 92-1993 for proper placement
- (3) Verify input voltage to model being used
- (4) Maximum loop resistance 100 ohms. Verify contact rating of End of Line Relay
- (5) Jumper must remain installed for two wire installation (see "Two Wire/Single Delay" figure, next page)
- (6) Jumper must remain installed if not using this option
- (7) All fuses 2AG Fast Acting
- (8) **End of line relay as per U.L. 864.** See smoke detector installation instructions for proper End of Line Relay p/n and contact ratings.

Installation of all wiring and related connecting hardware must be performed in accordance with the latest FPA, U.L. and N.E.C. standards and codes. In addition, all installations subject to Canadian standards shall be performed in accordance with the Canadian Electrical Code, Part I, with respect to wiring material type, wiring gauge related to power capacity requirements and circuit length and wiring methods.

TWO WIRE/SINGLE DELAY

High voltage connections

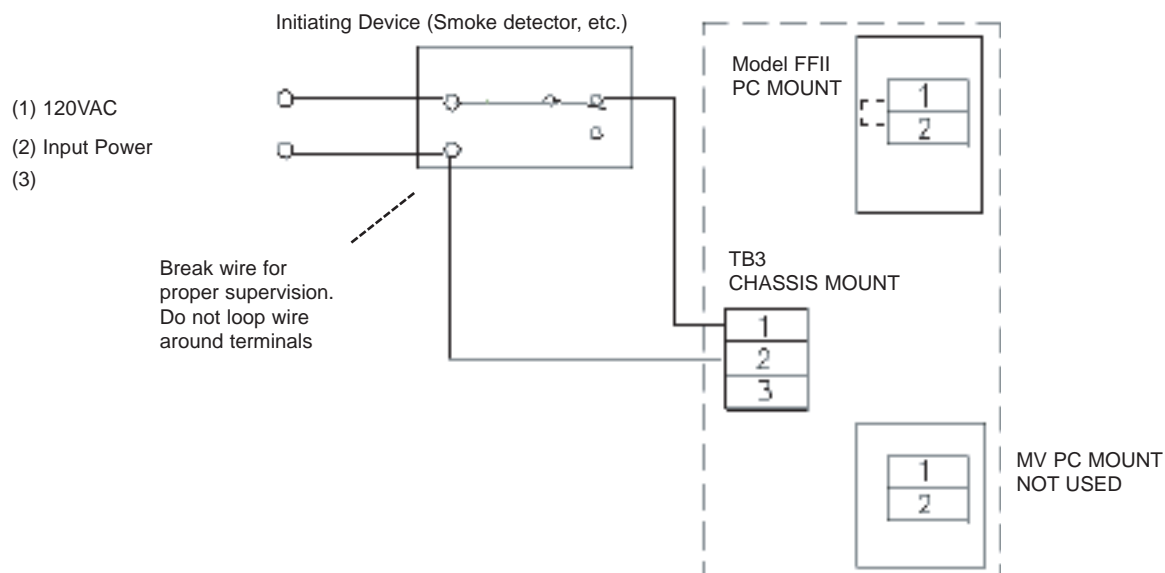

Low voltage connections

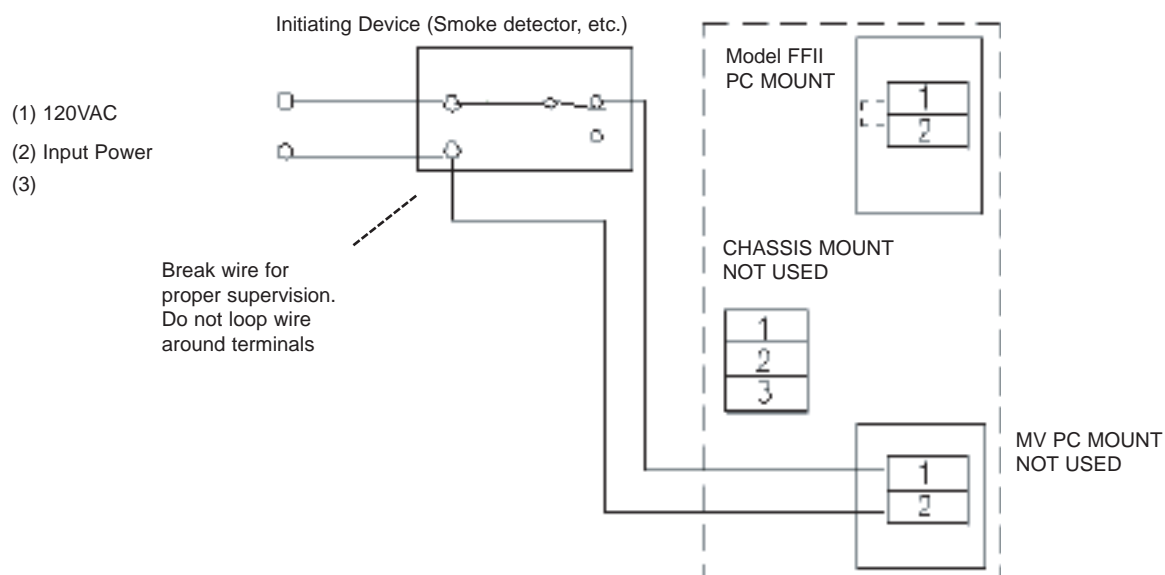

- (1) See NFPA 80 and NFPA 92-1993 for proper placement
- (2) Verify input voltage to model being used
- (3) See smoke detector installation instructions for contact ratings. Installation of all wiring and related connecting hardware must be performed in accordance with the latest NFPA, U.L. and N.E.C. standards and codes. In addition, all installations subject to Canadian standards shall be performed in accordance with the Canadian Electrical Code, Part I, with respect to wiring material type, wiring gauge related to power capacity requirements and circuit length and wiring methods.
- (4) Jumper must remain installed for two wire installation
- (5) All fuses 2AG Fast Acting.